

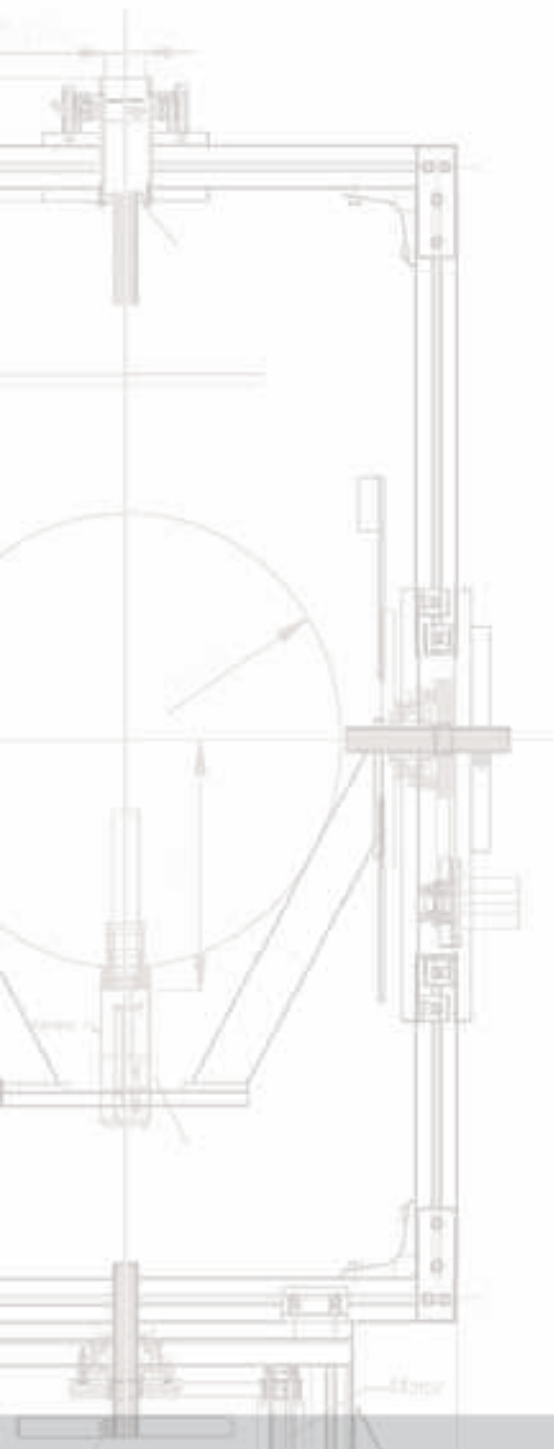

**TechnoTeam**  
Bildverarbeitung GmbH



# NEAR-FIELD GONIOPHOTOMETER

**801**  
**RIGO**

The full determination of the data of luminaires and lamps becomes more and more important:

- ❖ Primary prerequisite of a correct illumination planning
- ❖ Simulation, development of luminaires and lamps
- ❖ Cataloging and presentation

The goniophotometer type **RIGO 801** utilizes a new image-resolving CCD measuring technique for determining ray data and luminous intensity distributions.

The correct determination of the luminous intensity distributions (LVK) of lamps and luminaires is performed far within their photometric limiting distance on the basis of image-resolved measurements of luminous intensity distributions. A CCD-camera is moved by a goniometer around the measuring object at rest on a spherical surface, with the radius of this sphere being fixed only by the field angle of the camera. Thus, the goniometer can also be installed in small laboratories.

Anordnung zur Messung der Lichtstärkeverteilungen von Leuchten und Lampen  
Gebrauchsmuster DE 297 06 488.6 v. 11.04.1997

Poschmann, R.; Riemann, M.; Schmidt, F.;  
Verfahren und Anordnung zur Messung der Lichtstärkeverteilung von Leuchten und Lampen; Patent DE 41 10 574 v. 30.3.1991



**RIGO**<sup>801</sup>

# NEAR-FIELD GONIOPHOTOMETER

## Advantages

- Full description of the light emission by ray data
- Small dimensions of the set-up
- Measuring in normal position

## Result data

- Luminous intensity distributions (LID)
- Ray data available in various formats (e.g. ASAP, SPEOS, RWR, Lucid-Shape, LightTools, Zemax)
- Processing and archiving of the LVK data in a photometric database (LumCAT)

## Technical data

- Type of the goniophotometer**  
Image-resolving according to Prof. Riemann
- Dimensions**  
Aprr. 3L\*3L\*3L  
L: max. luminaire/lamp dimension
- Min. distance between the C-layers**  
0.1°
- Min. distance between the radiation angles**  
0.1°
- Measuring time**  
Aprr. 25 min. for 2.5° x 2.5°
- Camera**  
CCD – digital camera (Kappa) LMK98-2, 13bits, V(λ) - filter
- Illuminance meter**  
Digital 18Bit, V(λ) – adapted

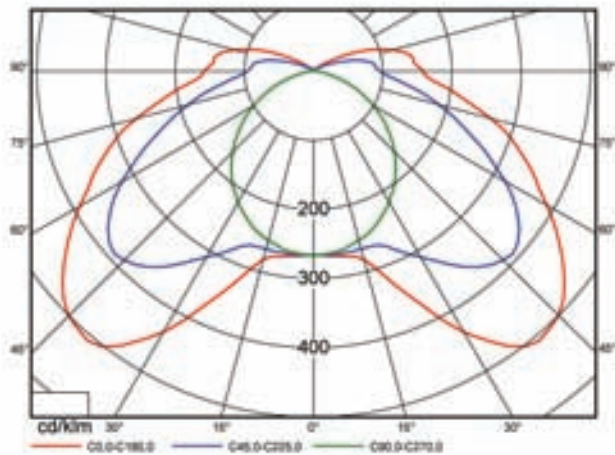

LID – point characterization

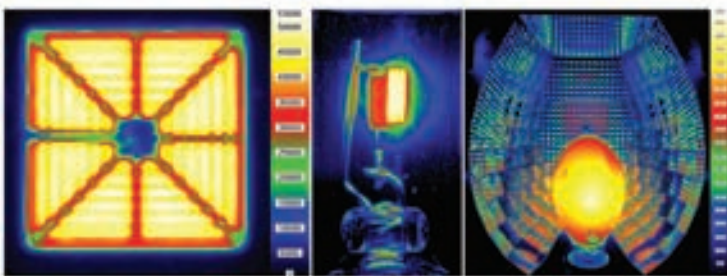

Luminance distribution of lamps/luminaires/LEDs

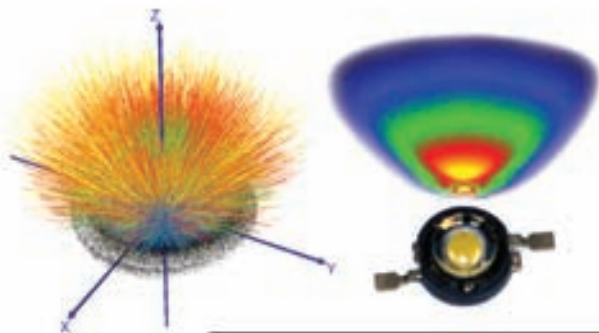

Ray model connected with the geometry

## Measurement of photometric objects

The measurement of photometric objects turns out to be necessary for various tasks:

- ✦ With respect to developmental aspects, the influence of modifications must be determined. The aim is to optimize the photometric parameters.
- ✦ Luminaires and lamps themselves are only components of a complete illumination system or of devices. For calculating such devices or systems, data are required which describe the luminaires/lamps.
- ✦ Descriptive data must be made available for marketing the products.

## Photometric measuring data

For describing photometric objects, not only simulation data but also various measuring data are necessary:

- ✦ **Light-emitting characteristic data of luminaires/lamps**  
(LIDs, spectral characterization; object assumed to be a point)
- ✦ **Description of the luminous surfaces of luminaires/lamps**  
(luminance distributions)
- ✦ **Light-emitting characteristic data of geometrically expanded luminaires/lamps**  
(4D-luminance distribution, ray distribution in the space)
- ✦ **Energetic description of the luminaires/lamps**  
(efficiency ratio, power input, temperature behavior)

## Its place in photometry

The photometric data of luminaires/lamps are measured by different types of measuring devices. In doing so, the radiation of light of luminaries is recorded on the basis of an evaluation from different observation directions.

The various measuring devices differ from each other in the following points:

- ✚ Either the measuring object is moved in order to set a defined radiation direction with regard to the photometric receiver, or the photometric receiver is moved in order to set a defined observation direction.
- ✚ Either only one photometric receiver is utilized which is positioned at a sufficiently large measuring distance (beyond the photometric limiting distance), or space-resolving or direction-resolving receivers are utilized which are positioned at a short measuring distance.

The following conventional types of measuring devices for determining photometric parameters can be classified:

- A | Goniophotometer with rotating mirror**
- B | Goniophotometer based on luminance measuring cameras**
- C | Goniophotometer with long measuring arm**
- D | Luminaire rotator**

Only type B, goniophotometer based on luminance measuring cameras, is able to generate measuring data for the radiation characteristics of geometrically expanded measuring objects for the calculation in the near field just as for the evaluation of luminance distributions on objects.

The measuring data of the luminous intensity distributions (LIDs) can be saved in all common file formats (EULUM-DAT, TM14, IES, Calculux) using the photometric database LumCAT. Ray data are made available in the formats of the simulation tools ASAP, SPEOS, LightTools, LucidShape and Zemax. In addition, also customer-specific formats can be realized.

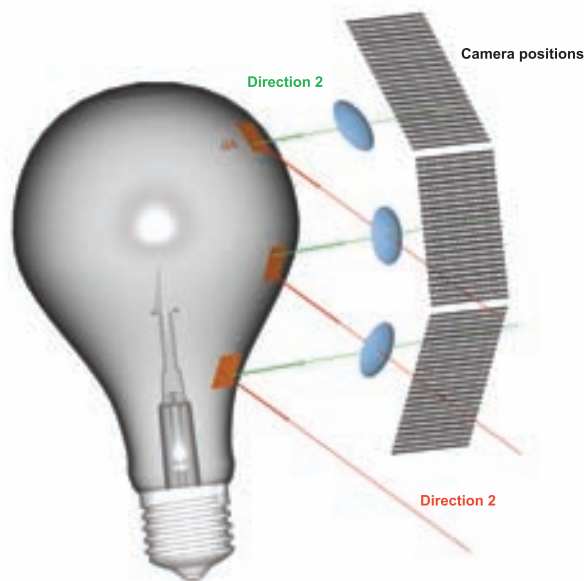
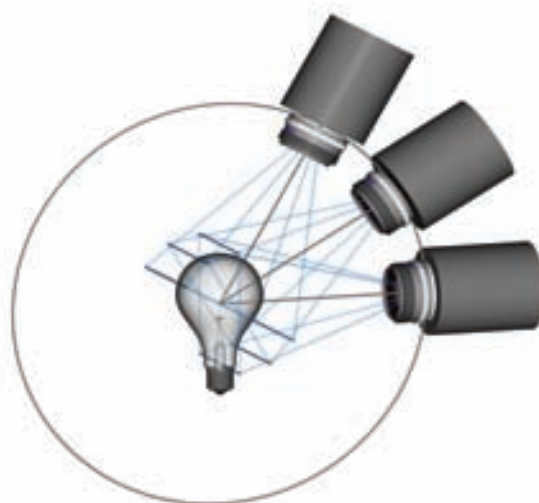

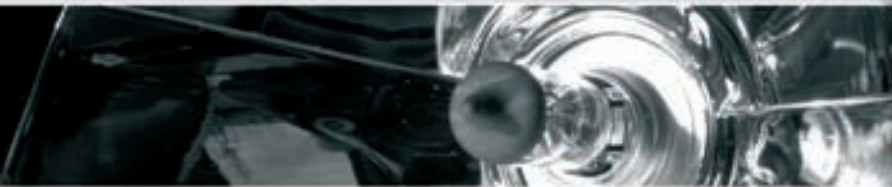

## Ray model basic data of the RIGÖ 801

For luminaire simulations (e.g. calculation of reflectors in headlamps), for the planning of illumination systems or for raytracing methods (computer simulation of living spaces and things like that), the data of the radiating/luminous objects are necessary. The full description of the radiation conditions of a surface requires to indicate the luminance distribution  $L_{x,y,z,\lambda}(\vartheta, \varphi)$  in all surface points  $(x,y,z)_{\text{Surface}}$  of the object. (Differing spectral distributions on the surface itself are not considered here.) As a surface can be described by two parameters  $z=f(x,y)$  - a 4D-data field results  $L(\vartheta, \varphi, x, y)$ .

The data records thus obtained permit the user to describe objects using ray models. Ray models are already used in many simulation programs. However, they are often based on synthetic, mathematically defined models for the luminous objects (e.g. description of a filament).

In some cases, model data may describe the actually used lamps and luminaires only insufficiently. Therefore, there is a high demand for measured data. If the luminance conditions on the surface (ray data) are to be determined, individual sensors which perform integral measurements cannot be employed. The required data can, in principle, be measured by means of an image-resolving luminance measuring camera (LMK)\* on a positioning unit (goniometer). This kind of measuring device is offered by the TechnoTeam company as RIGÖ 801 device in different versions. It has already stood its test in a big variety of different applications.

801  
RIGÖ

## Application of the measuring data

The measurement of the 4D-luminance distribution of measuring objects opens up new possibilities of describing photometric objects, integrating them into simulation programs, and obtaining data for documentation and planning. On the basis of the ray model, a big number of photometric parameters of luminaires/lamps can be determined using the **RIGO 801** device.

- ✦ Conventional planning data (LID) for light planning
- ✦ Data for near-field applications (Near-field LID)
- ✦ Luminance distributions
- ✦ Data for programs for the computer-assisted simulation of complex photometric assemblies

## Planning of illumination systems

The near-field goniophotometer type **RIGO 801** makes conventional luminous intensity distribution fittings (LID) of luminaires/lamps available.

At present, standard programs for the planning of illumination systems mostly use the luminous intensity fittings (LID) of luminaires as starting data. However, in the evaluation using LID, the luminaires/lamps are regarded only as point measuring objects, which is fully sufficient for many cases of application.

## Evaluation of luminance distributions

The internal database is the 4D-luminance data field, which resulted from 2D-luminance data measured at the respective observation positions (camera positions through goniometer control). Thus, also these original luminance images are available and can be evaluated using the LMK-functions (further information: <http://www.technoteam.de>).

The image-resolving measuring devices cannot only be combined with certain modules of image processing, but also with options for the recording and measurement of geometrical relations (lengths, angles, solid angles), thus permitting a big number of derived parameters to be obtained, too.

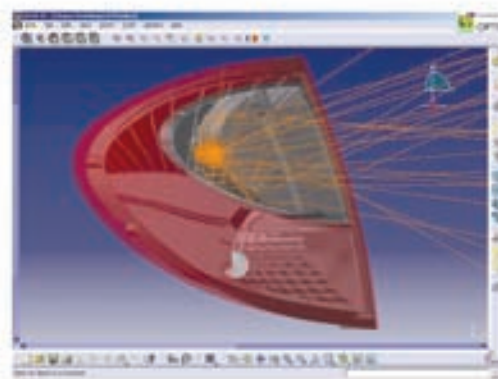

Simulation with measured ray data

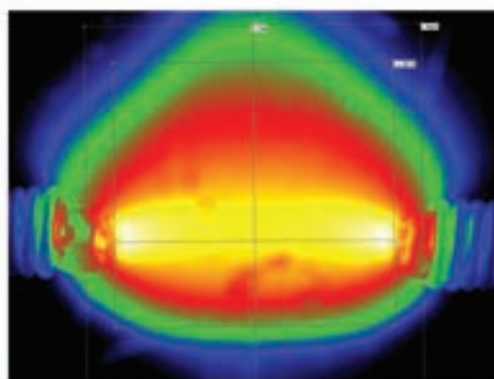

Evaluation of a luminance distribution on an arc (LMK – arc object, logarithmic representation)



Evaluation of a luminance distribution of a filament (LMK - filament, logarithmic representation)



## Full description of the luminous objects

For all those tasks where the data obtained as mentioned above are not sufficient, the complete measuring data can be used. This concerns, for example, the raytracing methods for reflector calculations on downlights or headlamps, the ray calculation of complex illumination systems (e.g. projectors) and others. The data records available after measurement can be converted into those formats used by the following simulation or evaluation programs.

## Technical data

The goniometers used for moving the image-resolving luminance measuring devices are realized according to the desired range of the measuring objects and also according to the available laboratory space.

## Applications

### Goniophotometer for LED and small lamps

Size of measuring object [ 6 x 6 x 6 mm<sup>3</sup> - 50 x 50 x 50 mm<sup>3</sup> ]  
Space required [ 600 x 600 x 800 mm<sup>3</sup> ]

### Goniophotometer for lamps and small luminaires

Size of measuring object [ 20 x 20 x 20 mm<sup>3</sup> - 300 x 300 x 300 mm<sup>3</sup> ]  
Space required [ 1300 x 1300 x 1900 mm<sup>3</sup> ]

### Goniophotometer for luminaires (according to customer's wishes)

Size of measuring object [ ≤ 2000 x 2000 x 2000 mm<sup>3</sup> ]  
Space required [ ≤ 4000 x 4000 x 4900 mm<sup>3</sup> ]

Relation between possible sizes of the measuring object and the space required by the measuring systems

## Goniometer for LEDs and small lamps

### Size of measuring object:

[ 6 x 6 x 6 mm<sup>3</sup> - 50 x 50 x 50 mm<sup>3</sup> ]

### Space required:

[ 600 x 600 x 800 mm<sup>3</sup> ]

### Movement:

The measuring camera and the illuminance meter are moved on a circular path around the lamp (horizontal  $\vartheta$ -axis). The lamp itself is turned around a vertical  $\varphi$ -axis.

### Travel path:

[  $\varphi = 0^\circ \dots 360^\circ$ ,  $\vartheta = -140^\circ \dots 140^\circ$  ]

### Measuring position of the luminaire:

Normal position, standing

### Measuring width:

[ 100 mm ]

### Positioning accuracy:

[  $\varphi < 0,02^\circ$ ,  $\vartheta < 0,05^\circ$  ]

### Repetitive accuracy:

[  $\varphi < 0,01^\circ$ ,  $\vartheta < 0,02^\circ$  ]

## GONIOMETER MODELS

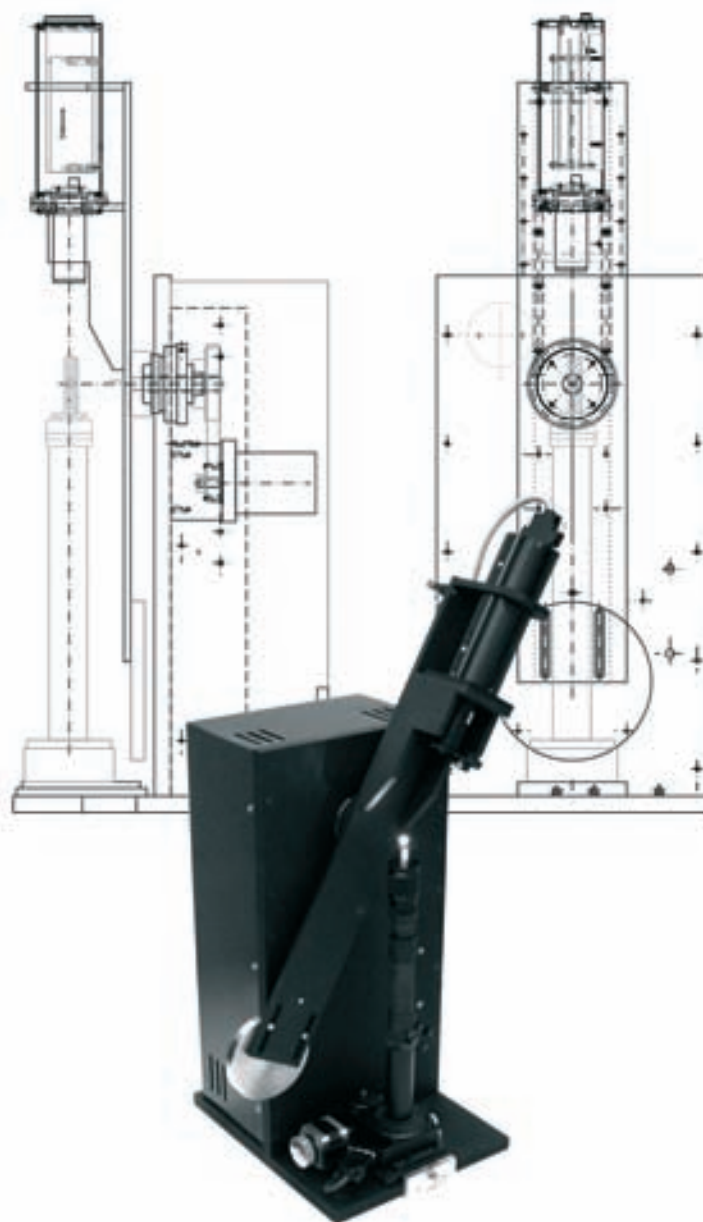

## GONIOMETER MODELS

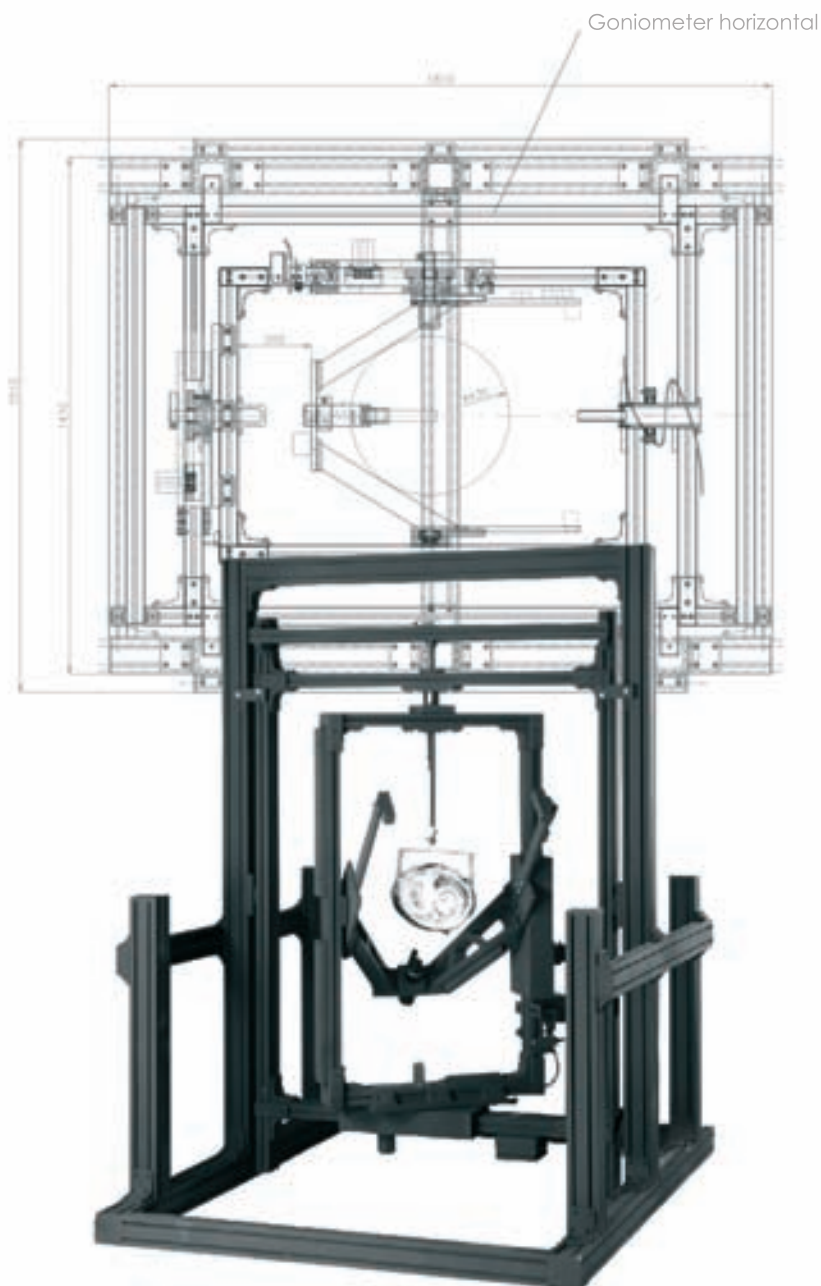

### Goniometer for lamps and small luminaires *swivelling*

#### Size of measuring object:

[ 20 x 20 x 20 mm<sup>3</sup> - 300 x 300 x 300 mm<sup>3</sup> ]

#### Space required:

[ 1300 x 1300 x 1900 mm<sup>3</sup> ]

#### Movement:

The measuring camera and the illuminance meter are moved on a sphere around the lamp (two independent axes arranged vertically to each other ( $\vartheta$ ,  $\varphi$ )).

#### Travel path:

[  $\varphi = -2^\circ - 362^\circ$ ,  $\vartheta = 0^\circ - 360^\circ$  ]

#### Measuring position of the luminaire:

Normal position, no movement of the measuring object. The whole goniometer can be swivelled, which permits different measuring positions to be realized.

#### Measuring width:

[ 270 mm ]

#### Positioning accuracy:

[  $\varphi < 0,02^\circ$ ,  $\vartheta < 0,05^\circ$  ]

#### Repetitive accuracy:

[  $\varphi < 0,01^\circ$ ,  $\vartheta < 0,02^\circ$  ]

801  
RIGÖ

## Goniometer for luminaires

### Size of measuring object:

[  $\leq 2000 \times 2000 \times 2000 \text{ mm}^3$  ]

### Space required:

[  $\leq 4000 \times 4000 \times 4900 \text{ mm}^3$  ]

### Movement:

The measuring camera and the illuminance meter are moved on a sphere around the lamp (two independent axes arranged vertically to each other ( $\vartheta$ ,  $\varphi$ )). mounted to a fixed upper point.

### Travel path:

[  $\varphi = -2^\circ - 362^\circ$ ,  $\vartheta = 0^\circ - 360^\circ$  ]  
(upper lamp suspension)

### Measuring position of the luminaire:

Normal position, no movement of the measuring object; lamp suspension possible at the top and at the bottom.

### Measuring width:

[ 500 - 2000 mm ]

### Positioning accuracy:

[  $\varphi < 0,02^\circ$ ,  $\vartheta < 0,05^\circ$  ]

### Repetitive accuracy:

[  $\varphi < 0,01^\circ$ ,  $\vartheta < 0,02^\circ$  ]

## GONIOMETER MODELS



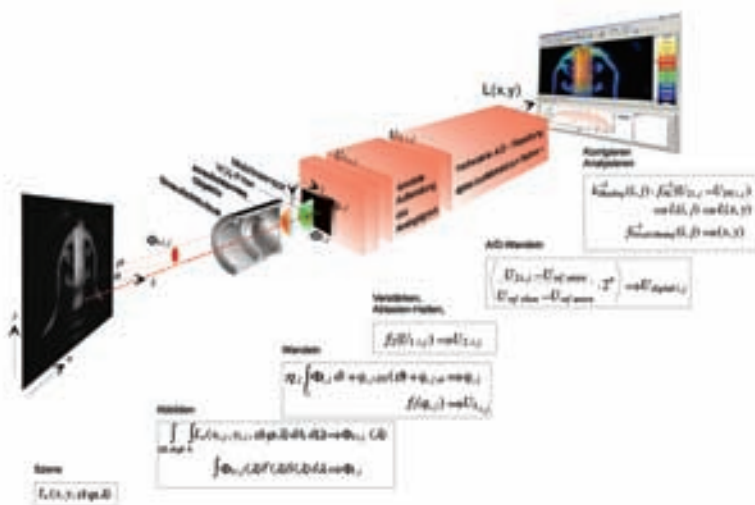

## Sensors

### Image-resolving measuring camera

- CCD – digital camera (Kappa), LMK98-3,  $V(\lambda)$  – full filter-adapted
- Digital framegrabber, 12/13 Bit
- Changeable lenses, photometrically corrected, distortion-corrected

### Illuminance meter

- $V(\lambda)$ -calibrated, cosine - adaptation
- Temperature-stabilised
- Digital signal output via RS422/232
- 18-bit resolution, 8 measuring ranges
- Usage of external photodiodes possible (e.g. UV measuring cells)

## Drives, control systems

Servomotors and Harmonic Drive gears.

## Evaluation computer

- ❖ Intel Pentium at least 2,6 GHz P4 CPU  
1 GB RAM
- ❖ CD-ROM-drive
- ❖ >40 GB E-IDE hard disk
- ❖ 19" Monitor
- ❖ WINDOWS 2000
- ❖ Digitaler Framegrabber
- ❖ Interface card (RS422)

## Software

### RIGO 801

Basic software for operating the goniometer.

- ❖ Capture of LIDs using the camera or illuminance meter, saving in the TechnoTeam – format, conversion into different standard formats using the software package LumCAT
- ❖ Angular step widths 0.1°... 2.5° (camera), 0.1°... 180° (illuminance meter)
- ❖ High measuring speed (e.g. 25 minutes for a 2.5° x 2.5° measurement).
- ❖ Capture of ray data, saving in the TechnoTeam format. Conversion using the program converter type 801 into various standard formats.

### Converter type 801

Program for the conversion of the TechnoTeam – ray data format into various standard formats.

- ❖ Presently available formats: ASAP, SPEOS, RWR, LucidShape, LightTools and Zemax.
- ❖ Presently available enveloping geometries: sphere, cylinder and cuboid.
- ❖ API for programming own raytracing - DLLs
- ❖ The output in custom-made formats is possible

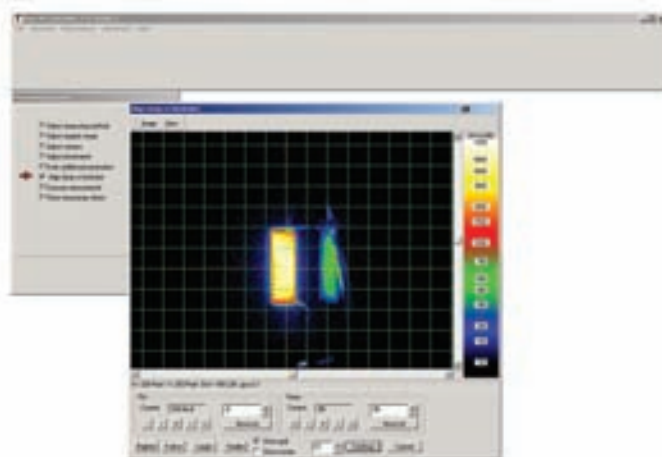

RIGO 801 - Measuring software

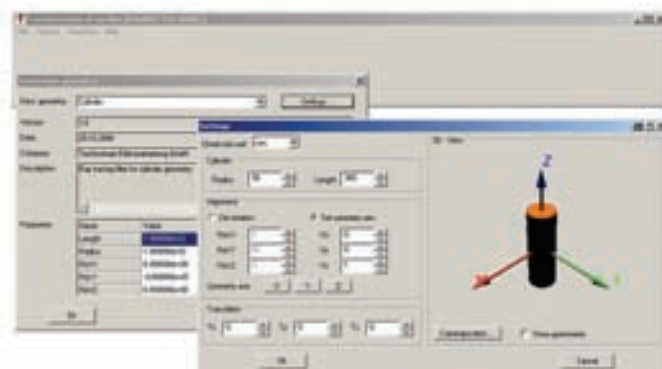

Converter 801 – Conversion into ray data formats



## Software

### LMK 2000

Luminance measuring software LMK 2000\*.

- Task-specific capture functions
- A variety of visualization functions
- Extensive statistical evaluations
- User-defined evaluation and drawing up of print reports
- Component for controlling the goniometer mechanics
- Special evaluation objects, e.g. spiral and arc object (ECE 99)

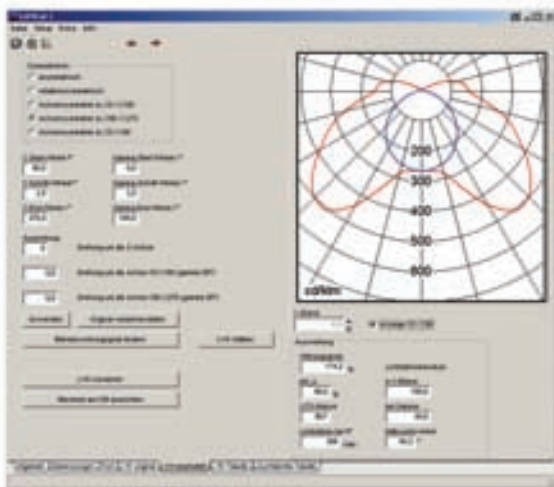

LumCAT

### LumCAT

- Conversion of the LVK-data from the TechnoTeam format into other formats (EULUM-DAT, TM14, IES, Calculux, ...)
- System for managing and processing luminaire data (database)
- Modification of all product information
- Drawing up of measuring protocols

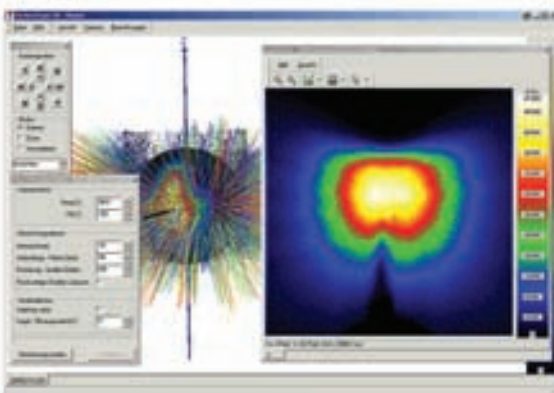

TechnoTeam 3D - Viewer

### TechnoTeam 3D – Viewer

Program for the 3D visualization of luminous intensity and ray distributions.

## Power supply and metrological equipment

### Zentro SX1H-X20S

A.C. voltage stabilizer  
200–254 V; 2,42kVA

### SSP 500-52 KA344A

DC-laboratory power supply 0...40V, 0...25A  
(Gossen-Metrawatt)

### Digital wattmeter type WT200

Yokogawa WT200, single-phase digital wattmeter, max. 600V, 20A, 0...50kHz

### Power Analyser NORMA 3000

LEM NORMA GmbH, 1 to 3 phases, max. 1000V, 10A, 0.1...110kHz

### Control panel

Control panel for the easy connection of power supplies, the multipurpose meter and the luminaire/lamp.

### Luminous flux general-lighting service lamp (LMT)

Incandescent lamp 24V/100W, matt socket E27

### Measuring lampholder for luminous flux general-lighting service lamp (LMT)

E27 socket with hard gold-plated contacts, additional measuring contacts



The components mentioned in this document such as a.c. voltage stabilizer, laboratory power supply, multipurpose meter and control panel can be installed in the goniometer switch cubicle and cabled upon customer's request.

# NEAR-FIELD GONIOPHOTOMETER

## References

Ansorg GmbH Lichttechnik, Mülheim a.d. Ruhr  
Austria Email Licht & Umwelttechnik GmbH, Wien  
D. Swarovski & Co. Lichtlabor Wattens, Österreich  
FH Ravensburg/Weingarten  
Goodrich Hella Aerospace, Lippstadt  
Hella KG Hueck & Co, Lippstadt  
Heraeus Noblelight GmbH, Hanau  
Lehner Werkmetall GmbH, Nittendorf  
LICHT Design Management Klinga b. Leipzig  
OSRAM GmbH, Herbrechtingen  
RZB Leuchten, Bamberg  
SITECO, d.o.o., Maribor  
Technische Universität Berlin  
Technische Universität Ilmenau  
Zumtobel STAFF GmbH & Co. KG, Lemgo

## TechnoTeam

Bildverarbeitung GmbH

Werner-von-Siemens-Straße 10  
98693 Ilmenau  
GERMANY

Tel. +49 3677 4624 0  
Fax. +49 3677 4624 10

Web. [www.TechnoTeam.de](http://www.TechnoTeam.de)  
E-Mail. [info@TechnoTeam.de](mailto:info@TechnoTeam.de)

801  
RIGÖ



Werner-von-Siemens-Str. 10 • 98693 Ilmenau, GERMANY • Tel. +49 3677 4624 0 • Fax +49 3677 4624 10 • [info@TechnoTeam.de](mailto:info@TechnoTeam.de)

[www.TechnoTeam.de](http://www.TechnoTeam.de)